

Hands-on session, steps to follow

Text in **red** indicates interaction with a GUI

Text in **brown** are commands to type/paste in a terminal

Text in **blue** is to be added to the file indicated

1. Prepare

1.1. Start VNC session

We are going to use a VNC session to run OpenFOAM and ParaView in this tutorial. OpenFOAM itself can also be run in the portal shell or using ssh. But ParaView requires rendering, so we'll use VNC here.

In a web browser, go to <https://portal-aces.hprc.tamu.edu>

Interactive Apps > VNC

Select:

2 hours

3 cores

5 GB of memory

Node Type : CPU Only

Launch

Once the VNC is started, open it and you will get a terminal. Commands can be pasted into the VNC clipboard and then to the terminal with Shift + Insert.

In Chrome, you often get a popup to allow access to the clipboard. By doing so, you can Shift + Insert directly without pasting to the VNC clipboard first.

1.2. Prepare terminal for running OpenFOAM commands

Right click the background and click "xterm" to open a new terminal to load OpenFOAM in. This will open a new terminal window.

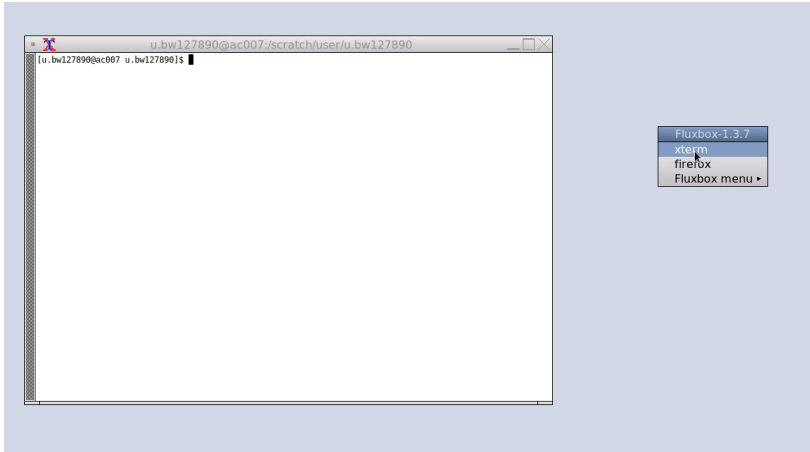

Minimize the **original** terminal and start typing the following commands in the **new** terminal.

A set of functions have been prepared for this course that will reduce the amount of typing needed. To load them:

```
source /scratch/training/openfoam/of_fcns
```

The of_fcns script simplifies some of the commands in the course. When the simplified commands are used, general ones are shown (grayed out) below for reference.

First, we need to load the OpenFOAM module:

```
loadOF10
```

OR, if you are doing this without the of_fcns script

```
module purge  
module load GCC/11.3.0 OpenMPI/4.1.4 OpenFOAM/10 NEdit/5.7.7  
source $FOAM_BASH
```

Note that the script also loads the NEdit module so we can look at and edit text files.

1.3. Create a place to run OpenFOAM cases

```
mkdir $SCRATCH/FOAM_RUN  
cd $SCRATCH/FOAM_RUN
```

1.4. Prepare a separate terminal for running ParaView

Again, right click the background and click “xterm” to open a new terminal to load ParaView in. This will open a new terminal window.

```
source /scratch/training/openfoam/of_fcns  
loadPV11
```

OR, if you are doing this without the of_fcns script

```
module purge  
module load ParaView/5.11.1-MPI-Linux64
```

Keep this terminal open in the background for now, **let's go back to the OpenFOAM terminal.**

2. Run windAroundBuildings tutorial

2.1. Copy tutorial case

```
copyFoamTutorial windAroundBuildings  
cd windAroundBuildings
```

OR, if you are doing this without the of_fcns script

```
cp -r $FOAM_TUTORIALS/incompressible/simpleFoam/windAroundBuildings .  
chmod --recursive +w windAroundBuildings  
cd windAroundBuildings
```

The following are the basic steps outlined in the Allrun script of the tutorial. Each OpenFOAM tutorial has an Allrun script that gives you an idea what tools are involved. You can simply run the Allrun script as **bash Allrun**. But we'll do it step by step here so we have time to talk about what is going on.

2.2. Create background mesh

```
blockMesh
```

2.3. Extract surface features/edges (optional)

snappyHexMesh can detect edges and refine around them, as well as snap the mesh to wrap nicely around corners. There seems to be a problem with the surfaceFeatures utility on ACES so we'll have to disable it for now. We'll do this by removing the line that picks out the edges in system/snappyHexMeshDict.

Normally, we'd type

```
surfaceFeatures
```

But that won't work here! To disable:

```
disableSF_10
```

OR, if you are doing this without the of_fcns script

```
sed -i '/buildings.eMesh/d' system/snappyHexMeshDict
```

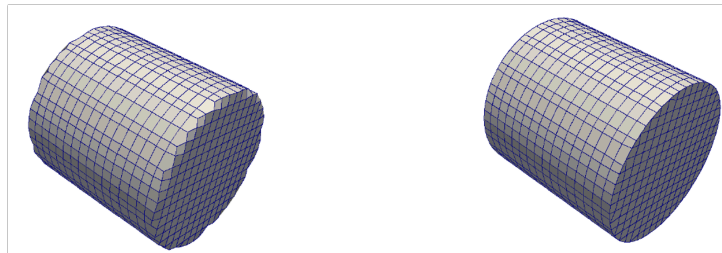

Mesh with/without edge snapping

2.4. Refine around object and snap mesh

```
snappyHexMesh -overwrite
```

2.5. Run incompressible solver

```
simpleFoam
```

2.6. Look at the results with ParaView

Switch to the ParaView terminal that we launched earlier.

Start by navigating to the windAroundBuildings case

```
cd $SCRATCH/FOAM_RUN/windAroundBuildings
```

Normally, ParaView can be launched using the `paraFoam` script. But we will load it manually here. ParaView has a built-in reader for OpenFOAM cases. It reads the case directly from the constant, system and [0-9] folders.

But the ParaView file reader interface requires a single file to be read. So we create a dummy (empty) file in the case directory with the file ending `.foam`. This will allow ParaView to read the whole case.

```
PV11_loadcase
```

OR, if you are doing this without the `of_fcns` script

```
touch buildings.foam  
paraview --data="buildings.foam"
```

In ParaView

When ParaView Loads, if not already selected, select `patch/buildings` under “Mesh Regions” (Scroll down from green “Apply” button”) Then click “Apply”.

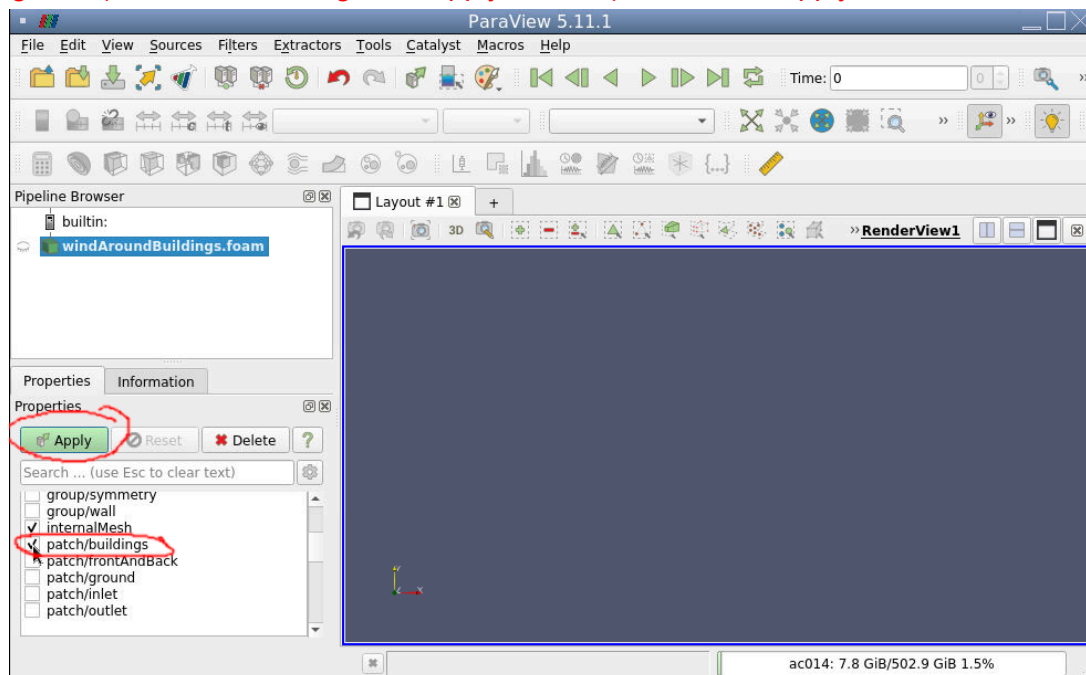

Extract building geometry

- In the top menu, Filters -> Alphabetical -> Extract block
- Select “buildings” patch
- Click “Apply”

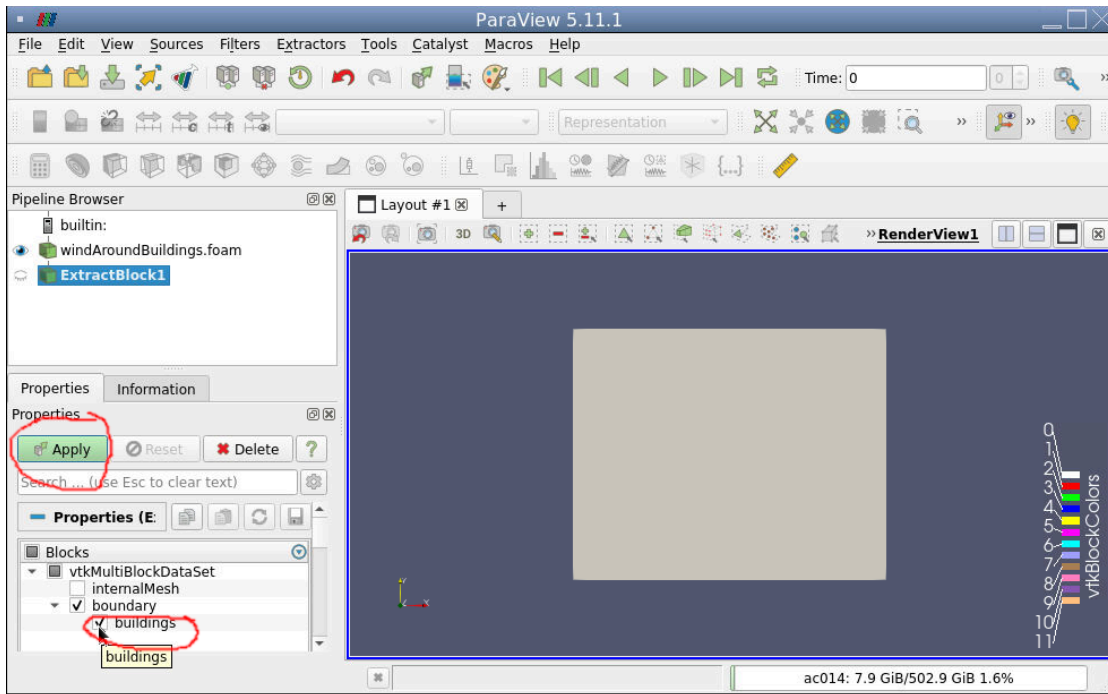

- Advance time to last time step (400) by clicking ►| in the case menu

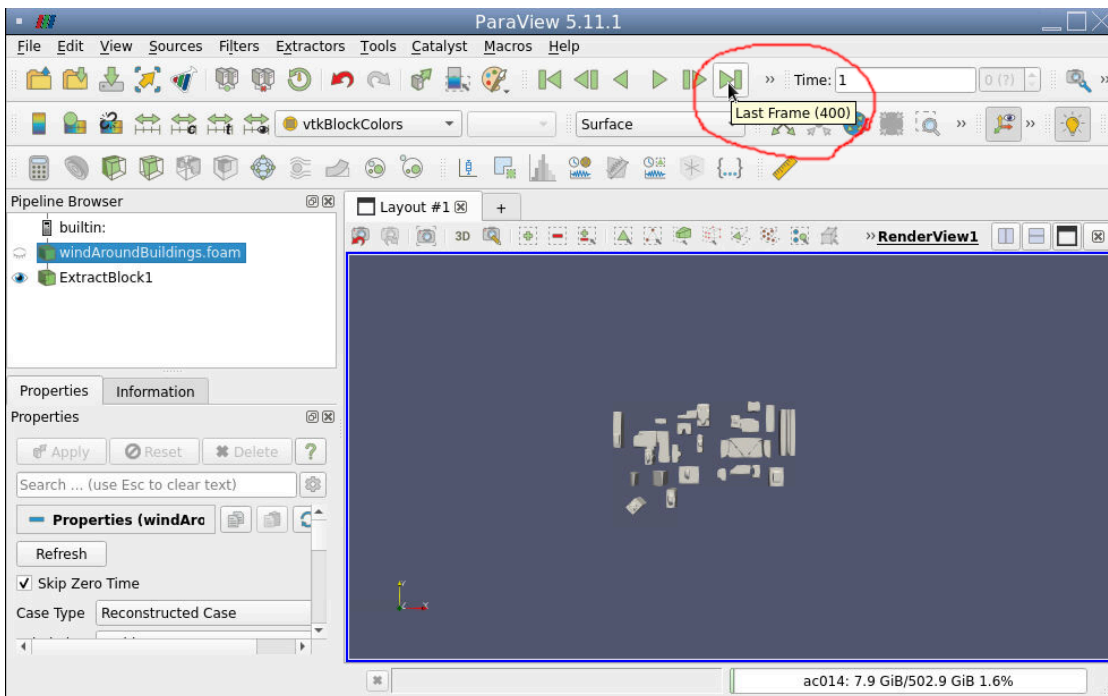

- Color by pressure by clicking “Solid Color” in the display menu and change to p

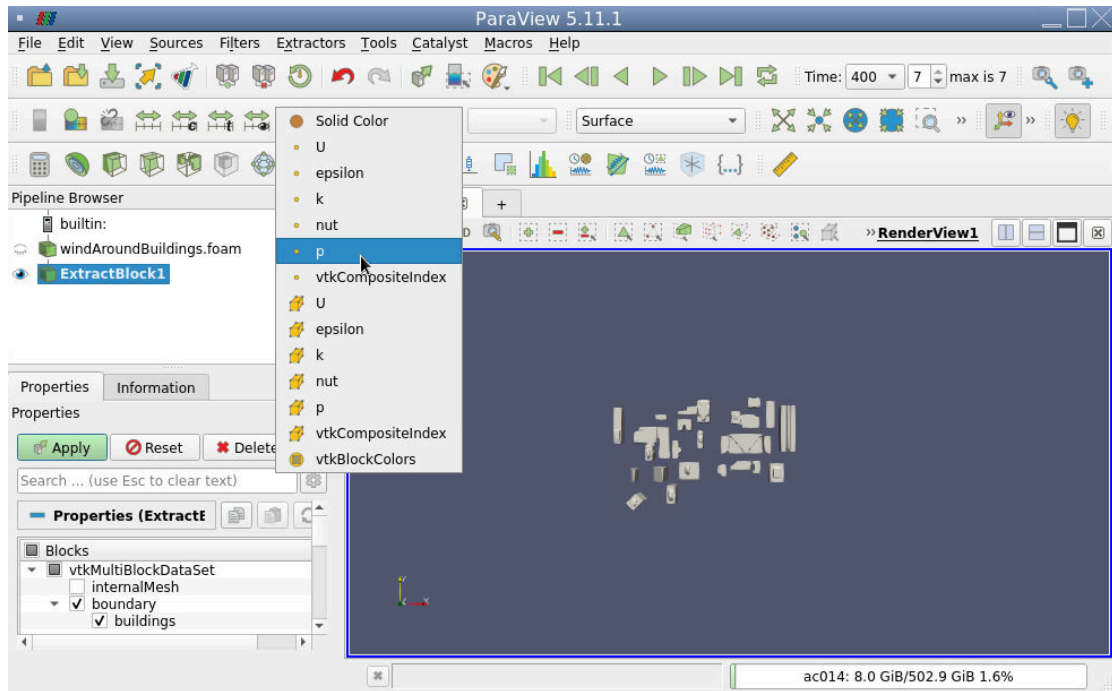

- Rotate to view result

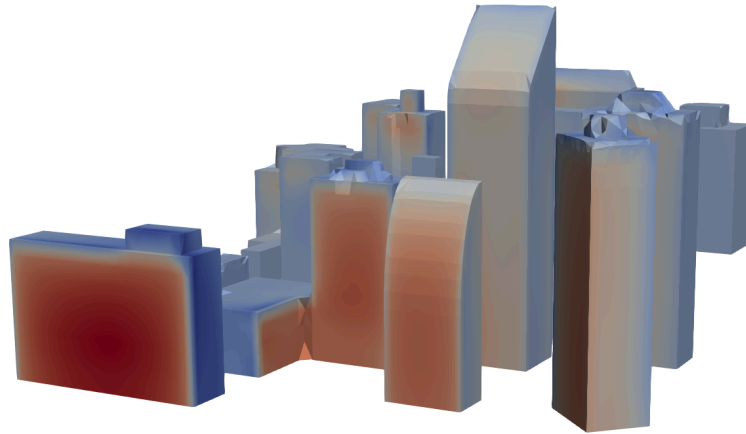

- Return to top view by clicking -z in the display menu. *This button may be hidden if your window is too small. If so, click the indicated “>>” button in the example below to show it.*

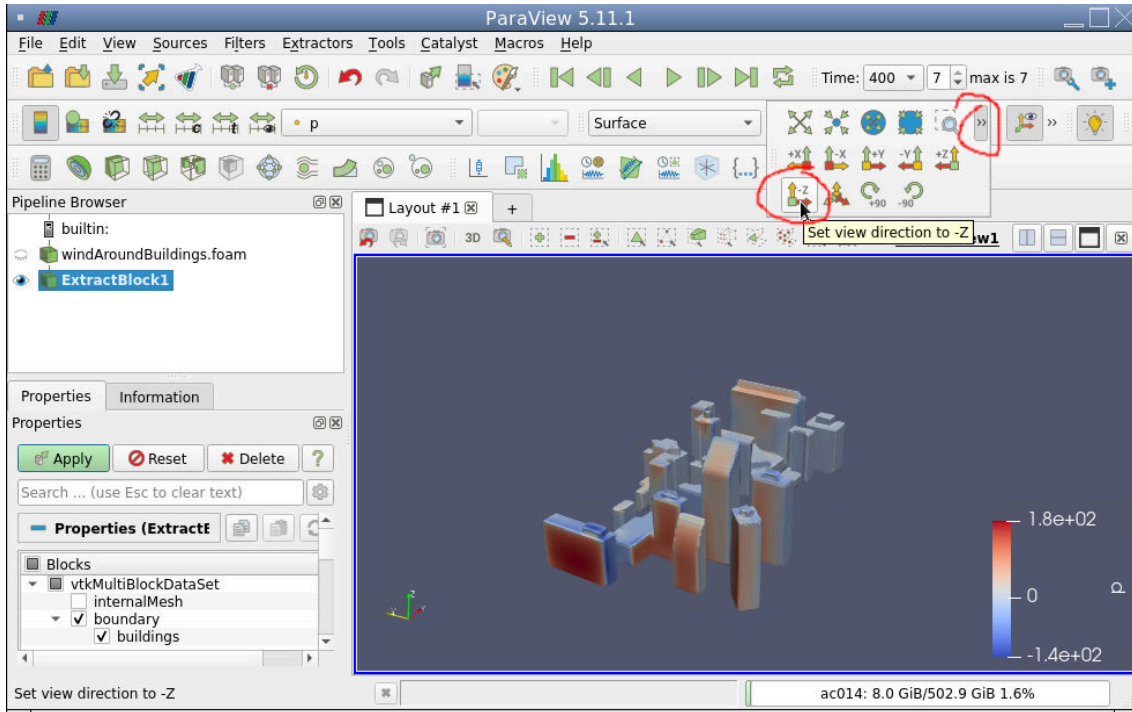

Make a slice to view velocity profile

- Click windAroundBuildings.OpenFOAM in the left pipeline browser and click "Slice" in the filters menu

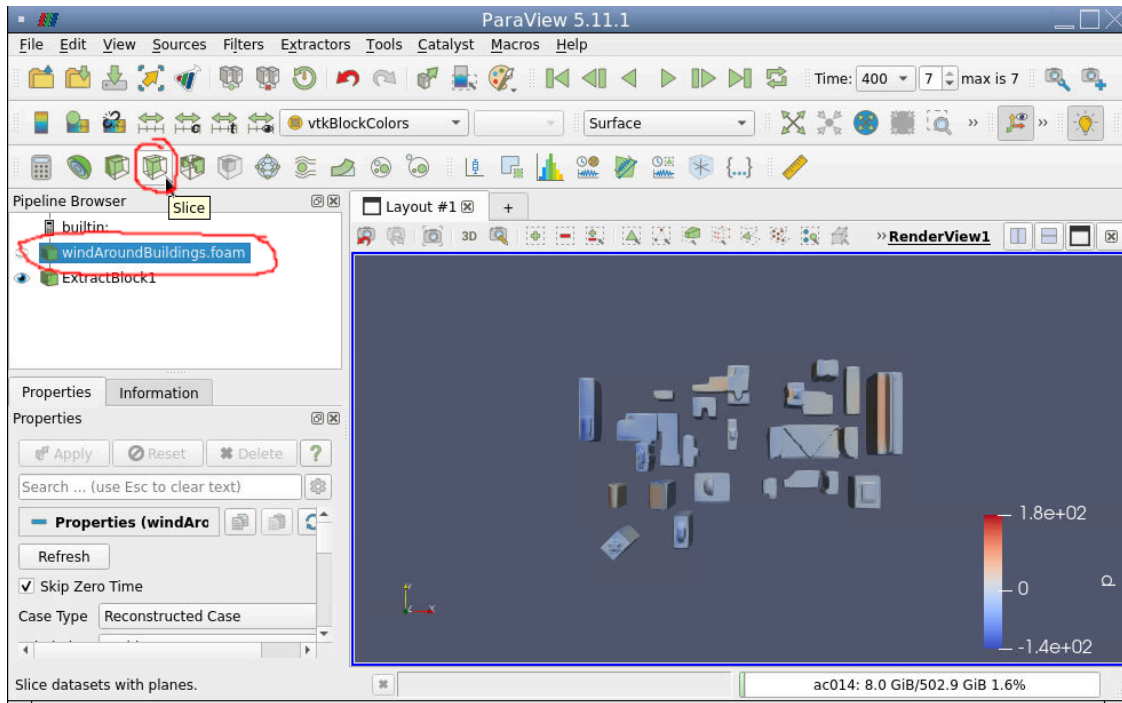

- Click “Z-Normal” in the properties of the slice and change origin z to 30m (x and y do not matter). Click Apply.

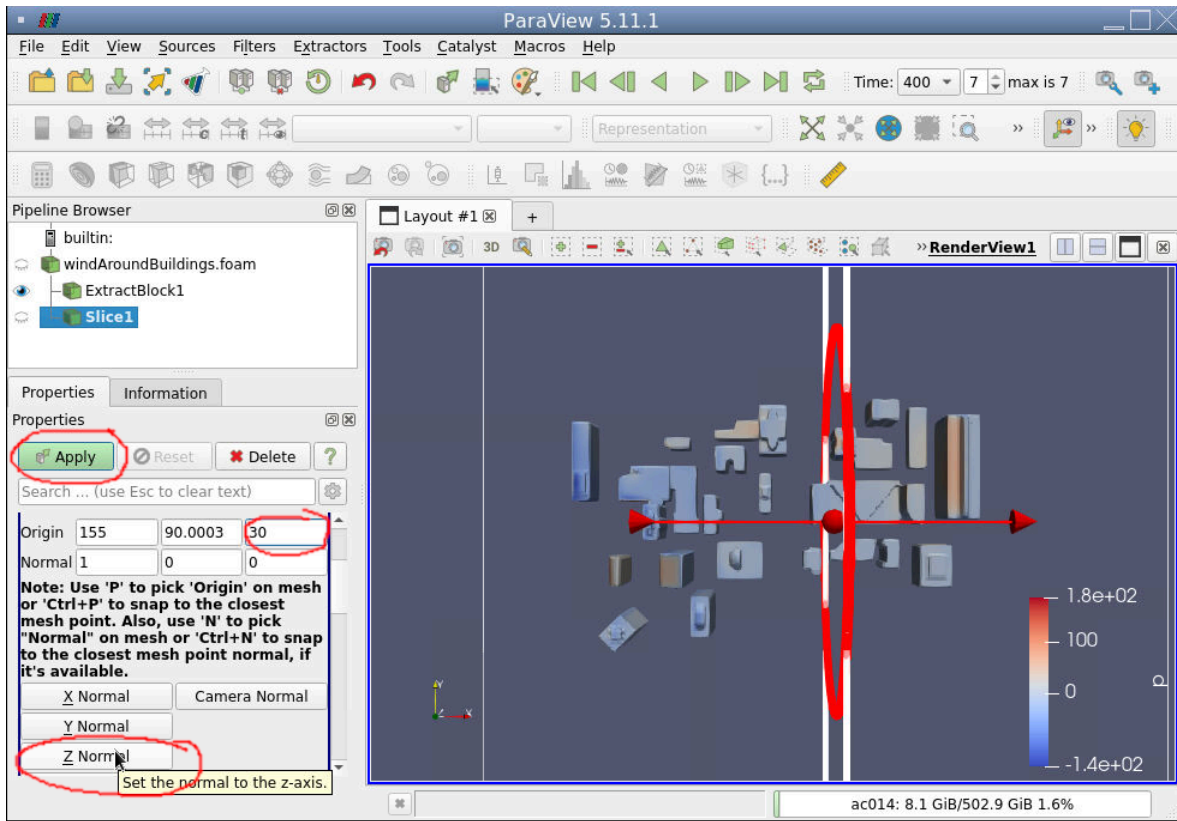

- Color slice by U (Same method as coloring buildings by p) and view results

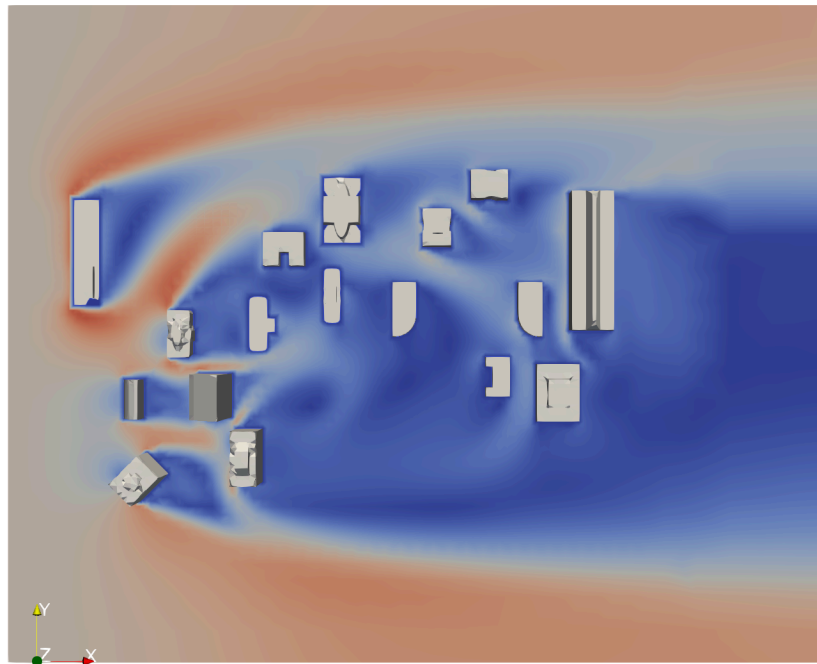

3. Modify windAroundBuildings tutorial

Since you are unlikely to find a tutorial for exactly your problem. The usual way to get started in OpenFOAM is:

- Find the tutorial that is closest to your problem. Meaning it has the key features you are looking for. Not necessarily the closest geometry. Geometry is “easy” to change.
- Modify the geometry, boundary conditions and/or solver settings to suit your needs.
- Success?

In this example, we will add a new building to the existing geometry from the tutorial and measure forces on it. The new building will be a cylindrical tower with a height of 225m and diameter of 50m.

3.1. Copy the case again

```
cd $SCRATCH/FOAM_RUN  
copyFoamTutorial windAroundBuildings windAroundNewBuilding  
cd windAroundNewBuilding
```

OR, if you are doing this without the of_fcns script

```
cd $SCRATCH/FOAM_RUN  
cp -r $FOAM_TUTORIALS/incompressible/simpleFoam/windAroundBuildings  
./windAroundNewBuilding  
  
chmod --recursive +w windAroundNewBuilding  
cd windAroundNewBuilding
```

3.2. Add the geometry for the new building

Let's make a simple cylindrical tower. Using the searchableCylinder geometry tool in OpenFOAM. We'll place it at x=150m, y=30m and have it extend from z=0m to z=225m. The radius of the building is 25m.

In snappyHexMeshDict:

Add in geometry
[newBuilding](#)

```

{
    type searchableCylinder;
    point1 ( 150 30 0);
    point2 (150 30 225);
    radius 25;
}

```

Add in refinementSurfaces

```

newBuilding
{
    level (3 3);           //Specify refinement level 3 on new bldg.
    patchInfo { type wall; } //Specify boundary type "wall"
}

```

3.3. Extend the domain to accommodate taller building

In blockMeshDict

Modify:

```

zMax 300;

```

3.4. Calculate forces and moments on the new building

In controlDict

Add in functions

```

forceCoeffs1
{
    type          forceCoeffs;
    libs          ("libforces.so");

    writeControl  timeStep;
    timeInterval  1;      //Write forces every time step
    log           yes;

    patches      (newBuilding); //What object to calculate forces on
    rho          rhoInf;      // Indicates incompressible
    rhoInf       1;          // Redundant for incompressible
    liftDir      (0 0 1);
    dragDir      (1 0 0);
}

```

```
CofR      (150 30 0); // Moment calculated around this point.
pitchAxis (0 1 0);
magUInf   10;
IRef      50; // Diameter
Aref      11250; // Projected
}
```

3.5. Repeat steps from tutorial

```
blockMesh
disableSF_10
snappyHexMesh -overwrite
simpleFoam
```

3.6. Plot forces over time

```
gnuplot
plot "postProcessing/forceCoeffs1/0/forceCoeffs.dat" using 1:2 with lines
exit
```

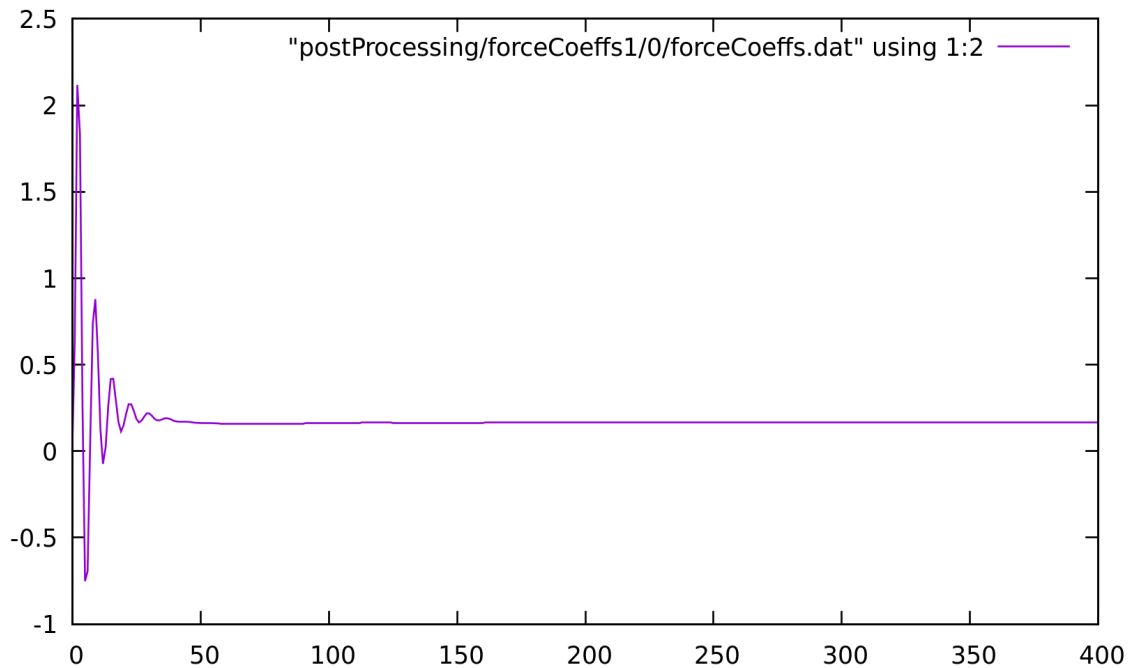

3.7. Look at the results with ParaView

Follow the same steps as in the tutorial. But when loading the case and applying the “Extract Block” filter, select both *buildings* and *newBuilding* blocks.

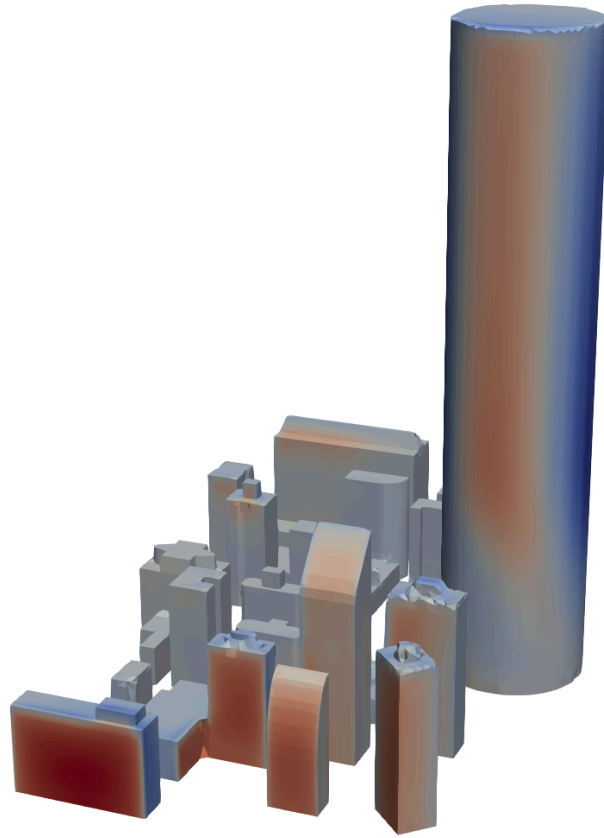

4. Running in parallel

4.1. Decompose the mesh

The `windAroundBuildings` tutorial doesn't have a dictionary for decomposing the mesh, so we'll copy one from another tutorial.

```
getDCPD
```

OR, if you are doing this without the `of_fcns` script

```
cp
$FOAM_TUTORIALS/incompressible/simpleFoam/motorBike/system/decomposePa
rDict system

chmod +w system/decomposeParDict
```

We'll edit the decomposeParDict to decompose into 3 domains.

In decomposeParDict

Modify:

```
numberOfSubdomains 3;
n (3 1 1);
```

Then we can decompose the mesh for parallel processing using the decomposePar command.

Clean up from previous run, remove all but zero time

```
rm -r [1-9]*
```

Decompose the case

```
decomposePar
```

4.2. Run simpleFoam in parallel

```
mpirun -np 3 simpleFoam -parallel
```

Running in serial took about 180 seconds and this took about 60 seconds (180/3). So it scales pretty ideally in this case!

5. Modify solver

5.1. Prepare a directory for custom applications

```
mkdir $SCRATCH/FOAM_APPS
cd $SCRATCH/FOAM_APPS
```

5.2. Copy an existing application

```
cp -r $WM_PROJECT_DIR/applications/solvers/incompressible/icoFoam
my_icoFoam

chmod --recursive +w my_icoFoam

cd my_icoFoam

mv icoFoam.C my_icoFoam.C

sed -i 's/icoFoam/my_icoFoam/g' Make/files

sed -i 's/FOAM_APPBIN/FOAM_USER_APPBIN/g' Make/files
```

The last two commands are very important not to skip! Or you may overwrite the default solver.

5.3. Define the new field and make the solver read/write it.

In createFields.H

Add, just after “createPhi” :

```
#include "createPhi.H"
```

```
Info<< "Reading field myField\n" << endl;
volScalarField myField
```

```
(
    IOobject
    (
        "myField",
        runTime.timeName(),
        mesh,
        IOobject::MUST_READ,
        IOobject::AUTO_WRITE
```

```
),  
mesh  
);  
  
label pRefCell = 0;
```

5.4. Create a transport equation for the new field

We want to create a scalar transport equation for myField. Let's call the field F :

$$\frac{\partial F}{\partial t} + \nabla \cdot (\bar{U}F) - \nabla \cdot (\nu \nabla F) = 0$$

Let's put the equation in its own file for better readability.

```
touch myFieldEqn.H
```

In myFieldEqn.H

Add :

```
solve  
(  
    fvm::ddt(myField)  
    + fvm::div(phi, myField)  
    - fvm::laplacian(nu, myField)  
);
```

In my_icoFoam.C

Add, just after while(piso.correct()) :

```
while(piso.correct())  
{  
    #include "myFieldEqn.H"  
    volScalarField rAU(1.0/UEqn.A())
```

5.5. Compile the new solver

```
wmake
```

Note: If you are compiling a library rather than an executable, the command is `wmake libso`

5.6. Test the new solver

```
cp -r $FOAM_TUTORIALS/incompressible/icoFoam/cavity/cavity .
chmod --recursive +w cavity
cd cavity
```

Create the mesh

```
blockMesh
```

Make Boundary Condition for myField

Copy the boundary conditions from p

```
cp 0/p 0/myField
```

In 0/myField

Modify :

Make the field non-dimensional.

```
dimensions [0 0 0 0 0 0];
```

Set a fixed value of 1 at the top boundary. Set to zero on walls.

```
movingWall
{
    type fixedValue;
    value uniform 1;
}
fixedWalls
{
    type fixedValue;
    value uniform 0;
}
```

Define matrix solvers for myField

Now we need to define solvers and schemes for myField

In system/fvSolution

Add, in “solvers” sub-dictionary :

```
myField
{
    solver PBiCG;
    preconditioner DILU;
    tolerance 1e-5;
    relTol 0;
}

myFieldFinal {$myField;}
```

In system/fvSchemes

Add, in “divSchemes” sub-dictionary :

```
div(phi,myField) Gauss linear;
```

Run the new solver!

```
my_icoFoam
```

Look at the results

In ParaView, load the case as with the tutorials, color by myField.

